



# The Main Concepts of the European Ground Systems – Common Core (EGS-CC)

Mauro Pecchioli, ESA/ESOC  
Juan María Carranza, ESA/ESTEC  
Presentation to GSAW  
March 2013

© 2013 by esa. Published by The Aerospace Corporation with permission.

1



# Background

- Within Europe, different monitoring and control systems are used by different organisations
  - Some of them common to Mission Operations and Spacecraft Assembly, Integration and Testing (AIT), some specific
  - Often multiple systems are used even within the same mission by different companies or at different levels (e.g. payload/system) or in different phases
  - Little synergy across missions and mission phases
  - Difficult to exchange data between various stakeholders
- Many of the existing systems have reached or are reaching their end of life
  - Become excessively complex with time
  - Use old software technologies and hardware platforms
  - Are difficult to maintain and modernise

# Objectives

- The EGS-CC Initiative aims at developing a common European M&C infrastructure enabling:
  - Seamless transition from spacecraft Assembly, Integration and Testing to Mission Operations
  - Overall cost reductions by sharing development, sustaining and maintenance of a single infrastructure
  - A reduction in the cost and risk associated to the implementation of space projects
  - The modernization of legacy Electrical Ground Support Equipment (EGSE) and Mission Control Systems (MCS)
  - The exchange of ancillary implementations across organizations

# Stakeholders

- EGS-CC is a collaboration of European large system integrators and space agencies to develop a common core
  - Astrium Satellites
  - Astrium Space Transportation
  - CNES
  - DLR
  - ESA ESOC
  - ESA ESTEC
  - OHB System
  - Thales Alenia France
  - Thales Alenia Italy
- Initiative considered strategic by all parties

# Collaboration Agreements

- Memorandum of Understanding between the EGS-CC partners
- Collaboration Agreement (legally binding) being finalised and signed
- Development of the EGS-CC in open competition according to ESA contract conditions and processes
- Adoption of the EGS-CC for institutional missions and then for commercial missions after successful operational validation in institutional missions
- Active stakeholders involvement at two levels:
  - Steering Board, owning the responsibility of defining and managing the implementation of policy related aspects (e.g. funding, procurement, evolution, licensing)
  - System Engineering Team, acting as a technical coordination body managing the definition and all technical aspects of the system

# Governance

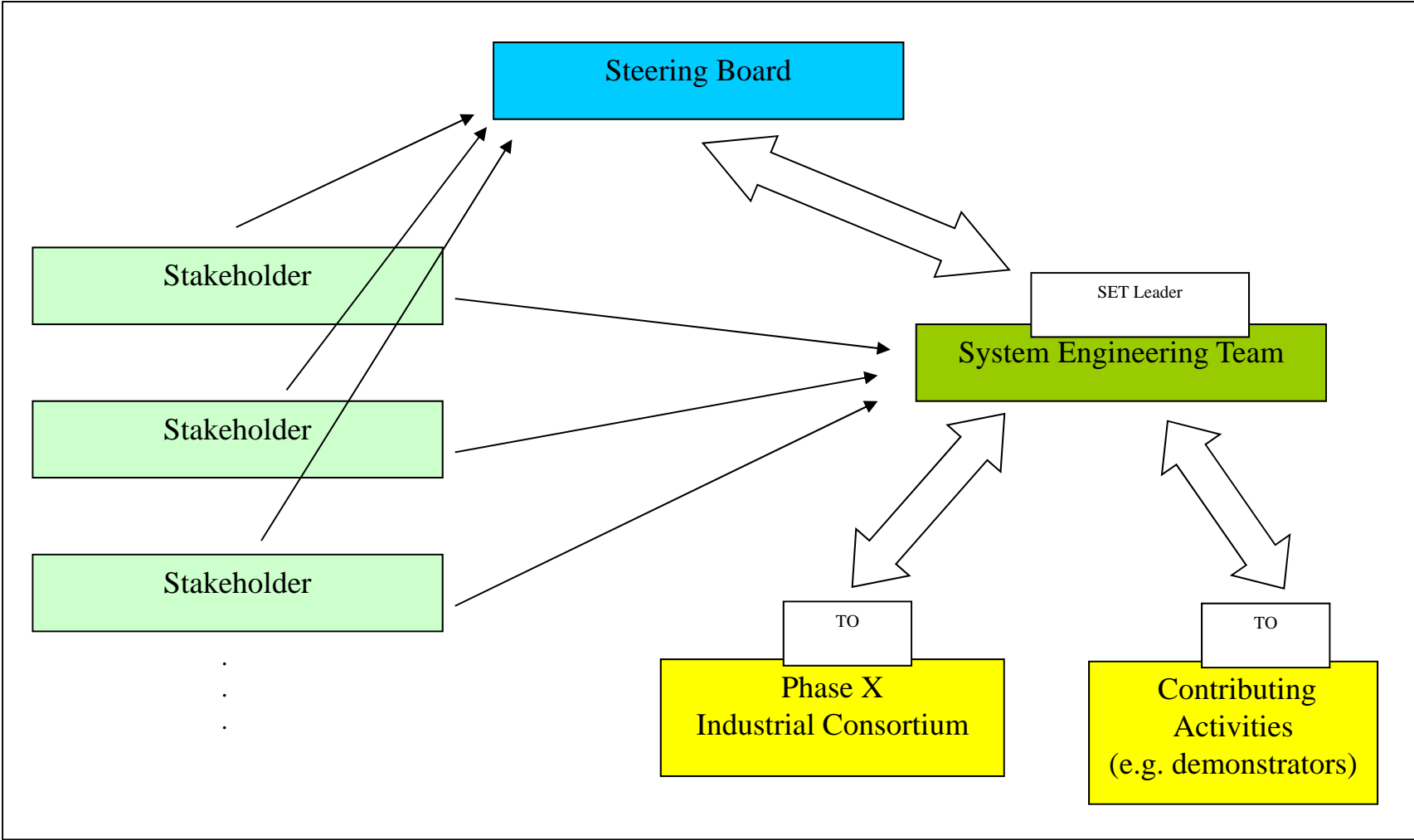

# Main System Features

- Scope of the EGS-CC system features is very ambitious
  - Support of all mission types and phases
  - Open, component based, service oriented architecture
  - Generic and extensible functionality
  - High performance and scalability
  - Layered implementation
  - Clear separation between generic M&C functions (kernel) and specific features of the controlled system (adaptation layer)
  - Binary compatibility
  - Standardised interfaces (as far as possible...)
  - Technology isolation (as far as possible...)
  - Long term maintainability

# Top Level Decomposition

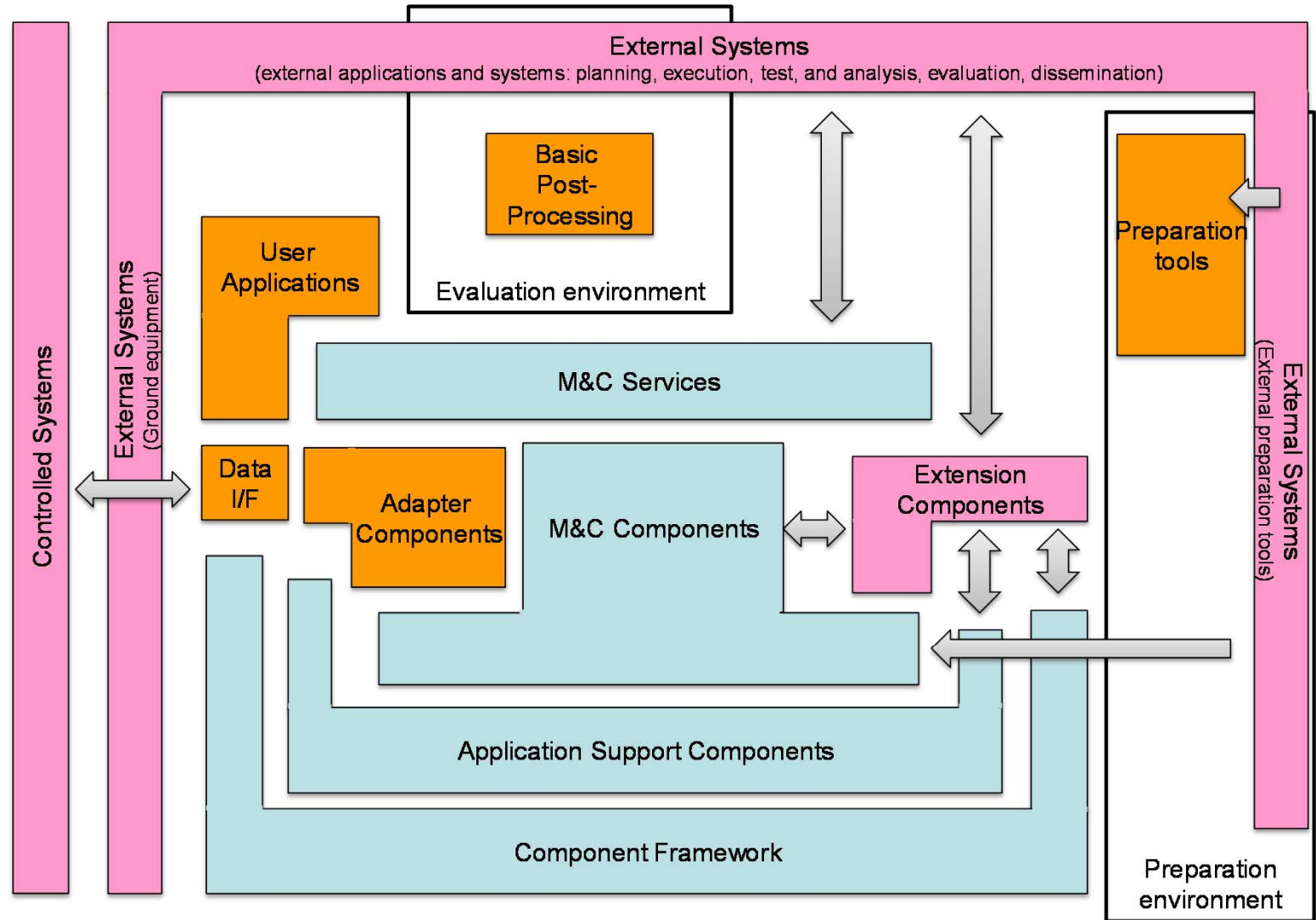

## Legenda

- Reference Test Facility
- Reference Implementation
- Kernel



# Architectural Layers

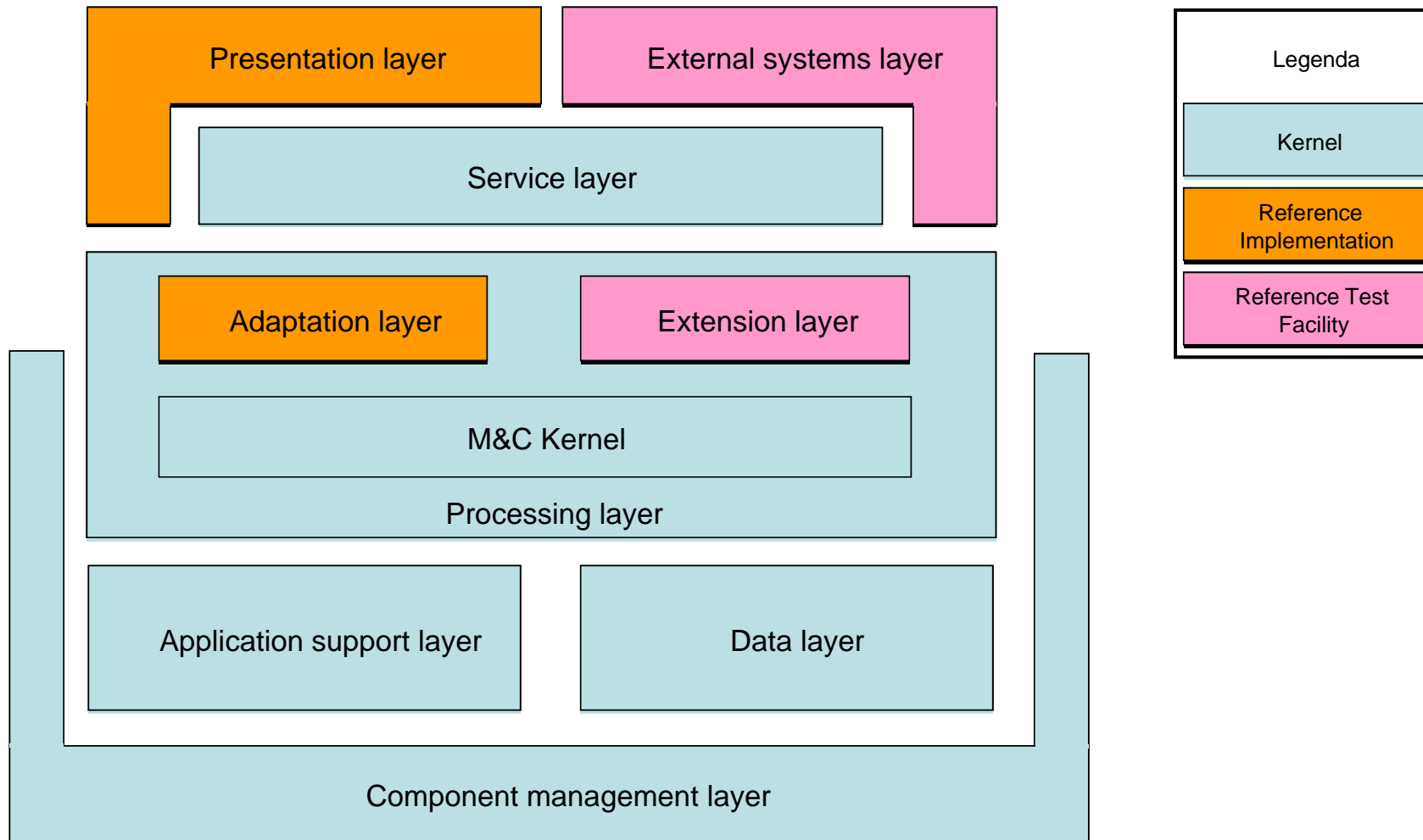

# Architectural Layers

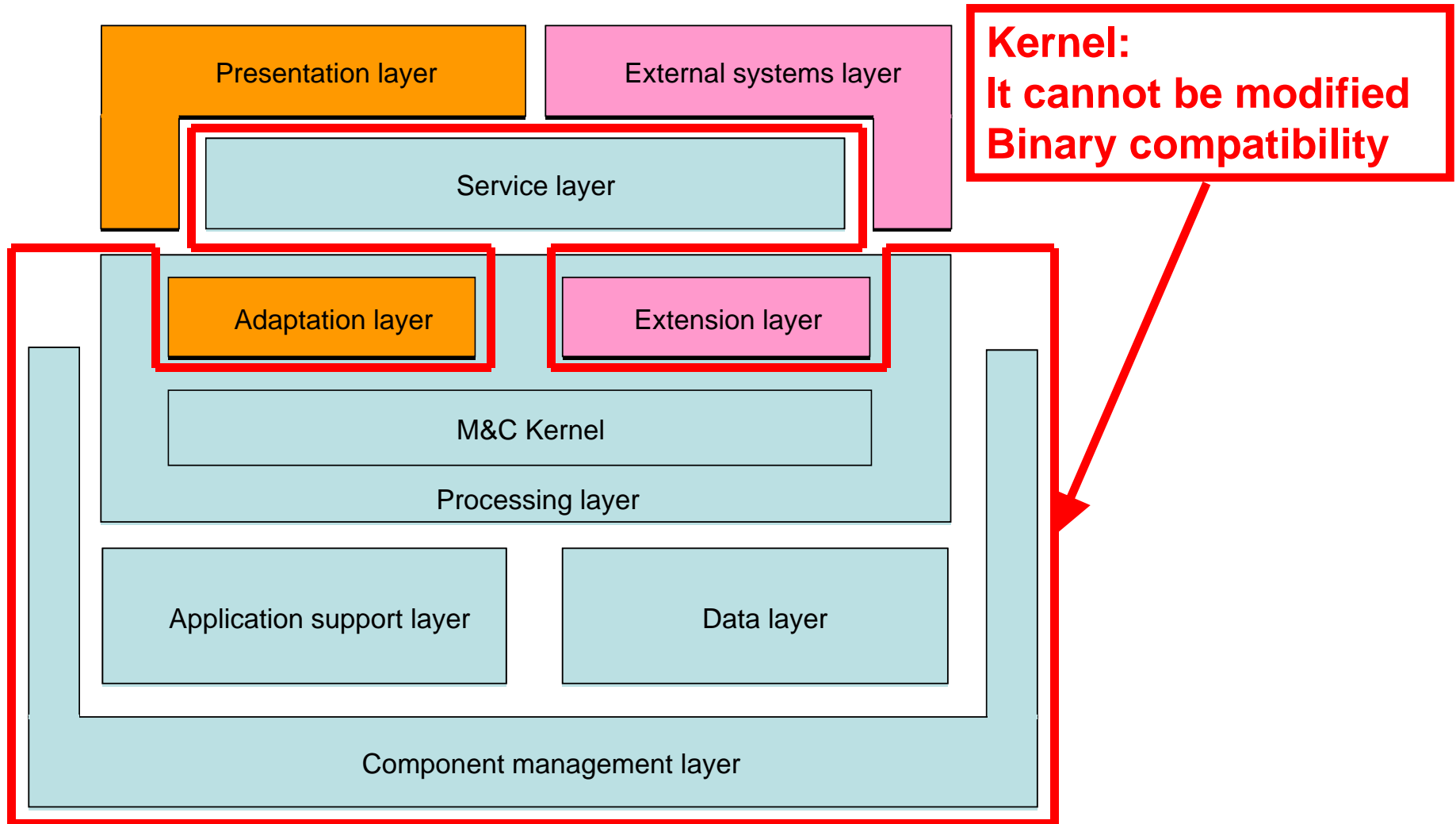

# Architectural Layers

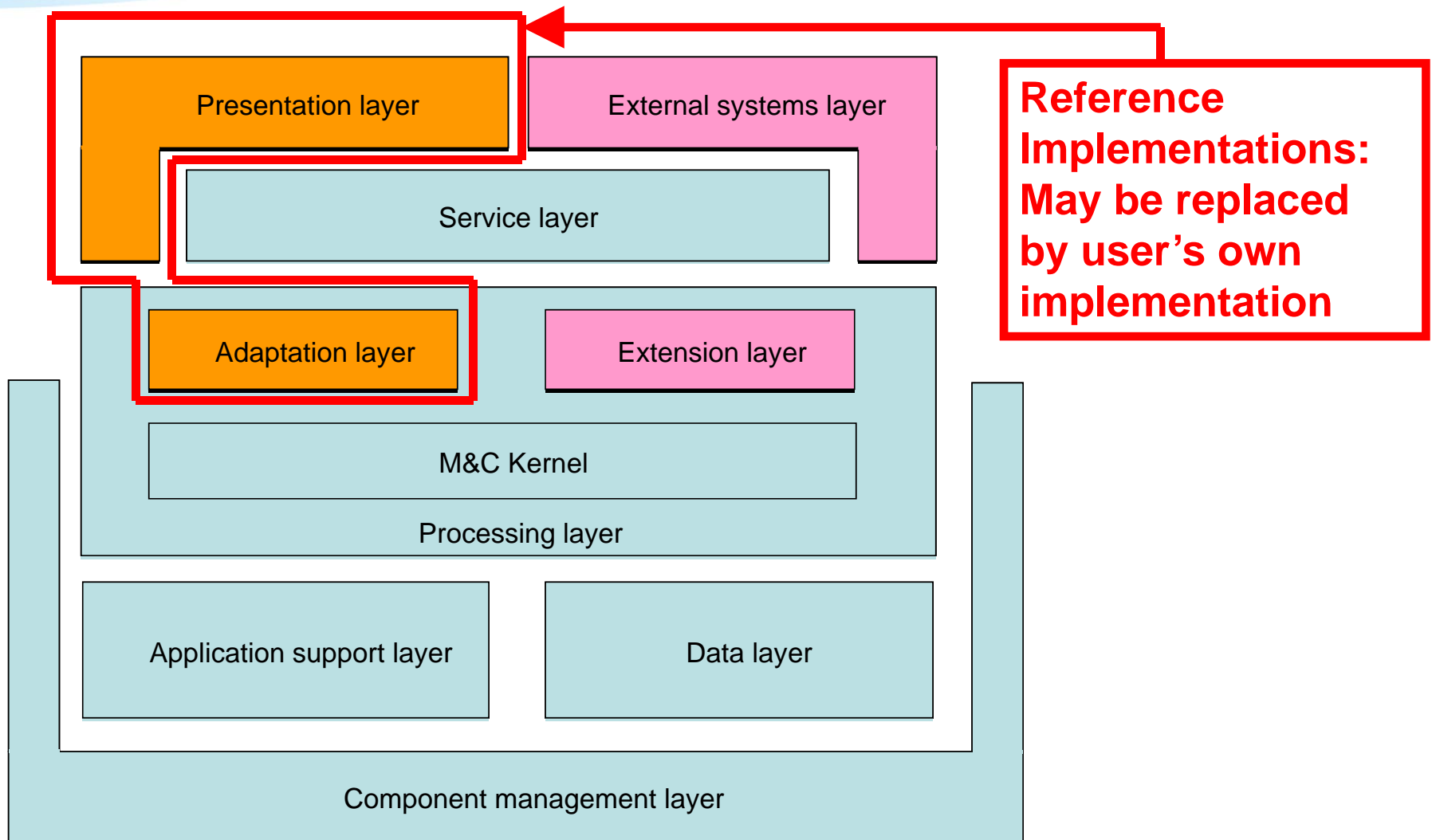

# Kernel Functional Scope

- Application support layer
  - Run-time (component) framework
  - System management and administration
  - Access control (security)
  - Time synchronisation
  - Data archiving
- Monitoring and Control components
  - Monitoring and Control Model
  - Control activities validation, scheduling, execution and verification
  - Commanding (control of the controlled system)
  - Procedures execution
  - Reporting data (parameters) processing
  - Event processing
  - Support of live, playback, retrieval and replay processing modes

# Reference Implementations Functional Scope

- Adaptation layer
  - TM/TC Data I/F handlers (based on CCSDS SLE)
  - Monitoring and control adapters (e.g. TM/TC receiver/releaser, SCOE I/F Protocols)
  - Modelling of M&C services of the controlled system (based on ECSS PUS)
  - Space/Ground time correlation
- User applications
  - User desktop
  - User defined displays (plots, synoptic, alphanumeric)
  - M&C applications (control stacks, history logs, alarm summary display)
  - System (administration and monitoring) displays
  - M&C Model browser (navigation tree)
- Off-line tools
  - Preparation tools
  - Basic post-processing and reporting
- External interfaces
  - Tailoring/configuration/archive data import/export
  - M&C services (based on CCSDS MO)
  - Many others (a long list...)

## *The Monitoring and Control Model*

- Functional core of the system
- Provides capability to model the complete space system from a monitoring and control standpoint, based on the Space System Model concept of ECSS E-70-31
- Acts as an abstraction layer for monitoring and control operations (through a hierarchy of System Elements)
- Encapsulates the main monitoring and control functions (e.g. parameter processor, activities handler, events processor)
- Provides access to all data of M&C relevance (static definitions and dynamic state)
- Interacts with the engineering data archive to store all generated data of operational relevance for later retrieval/replay
- Supports the provision of M&C services to external components

# Hierarchical M&C Model

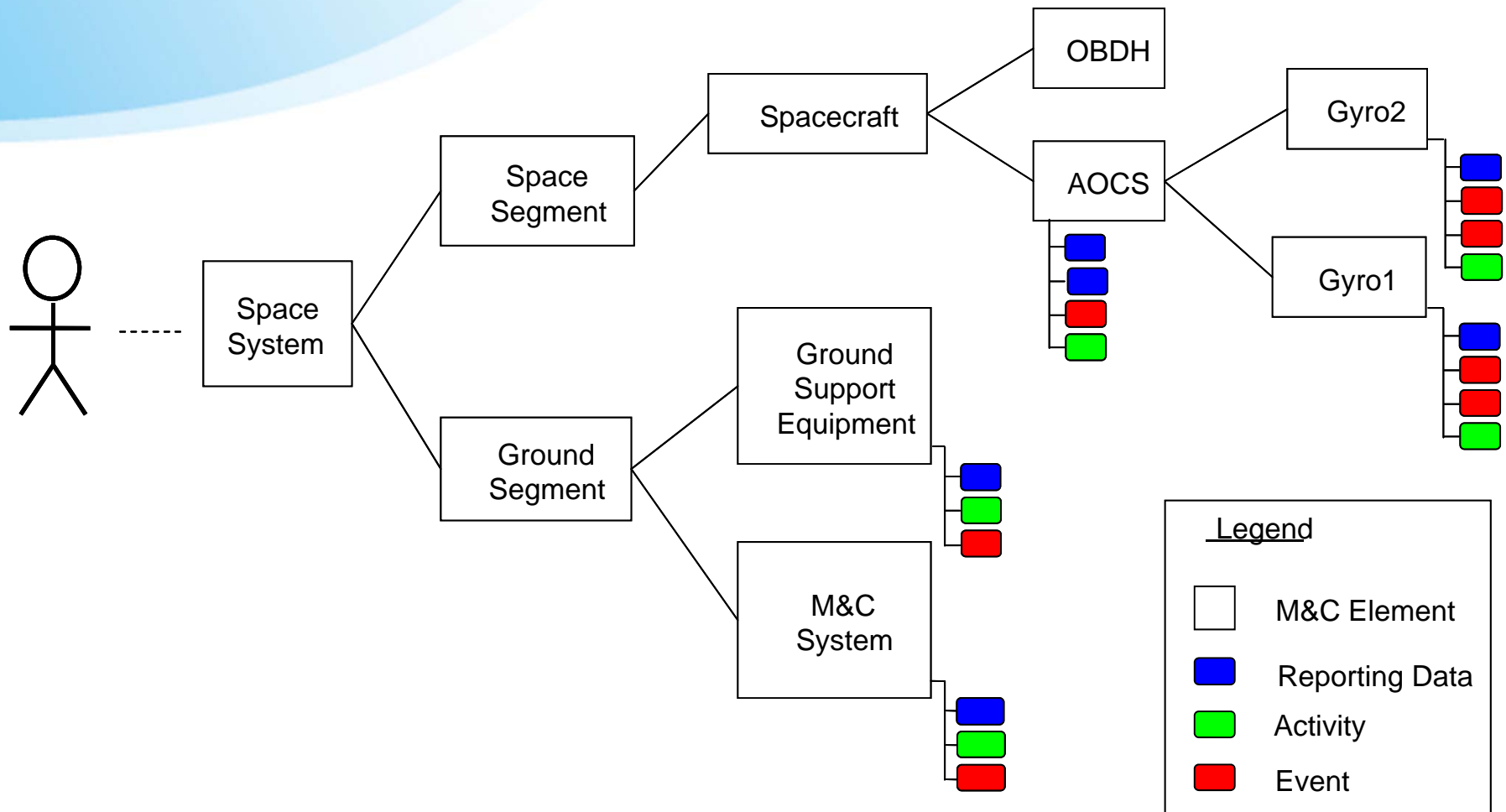

# MCM Data Access Layer

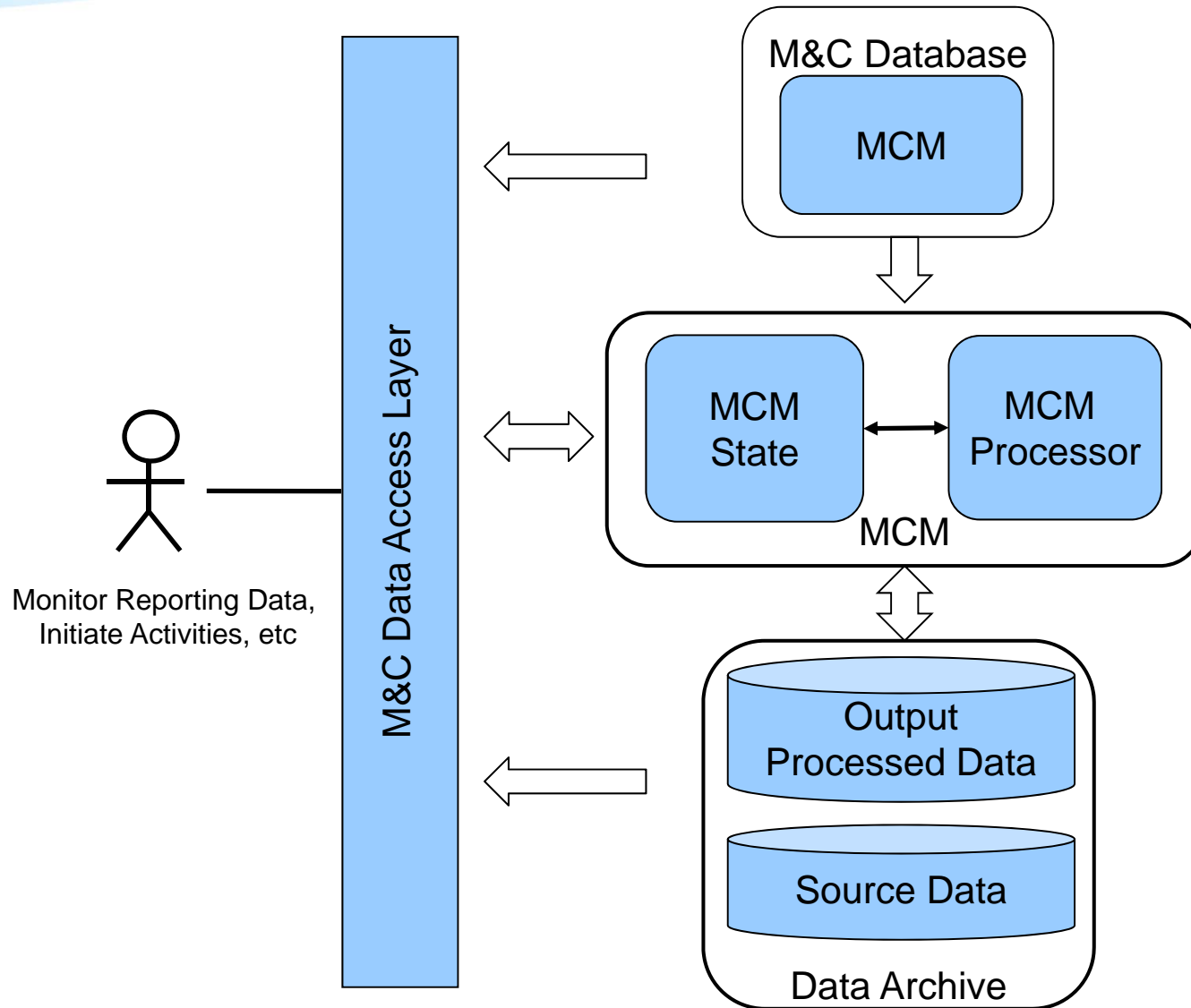



# Data Processing Concept

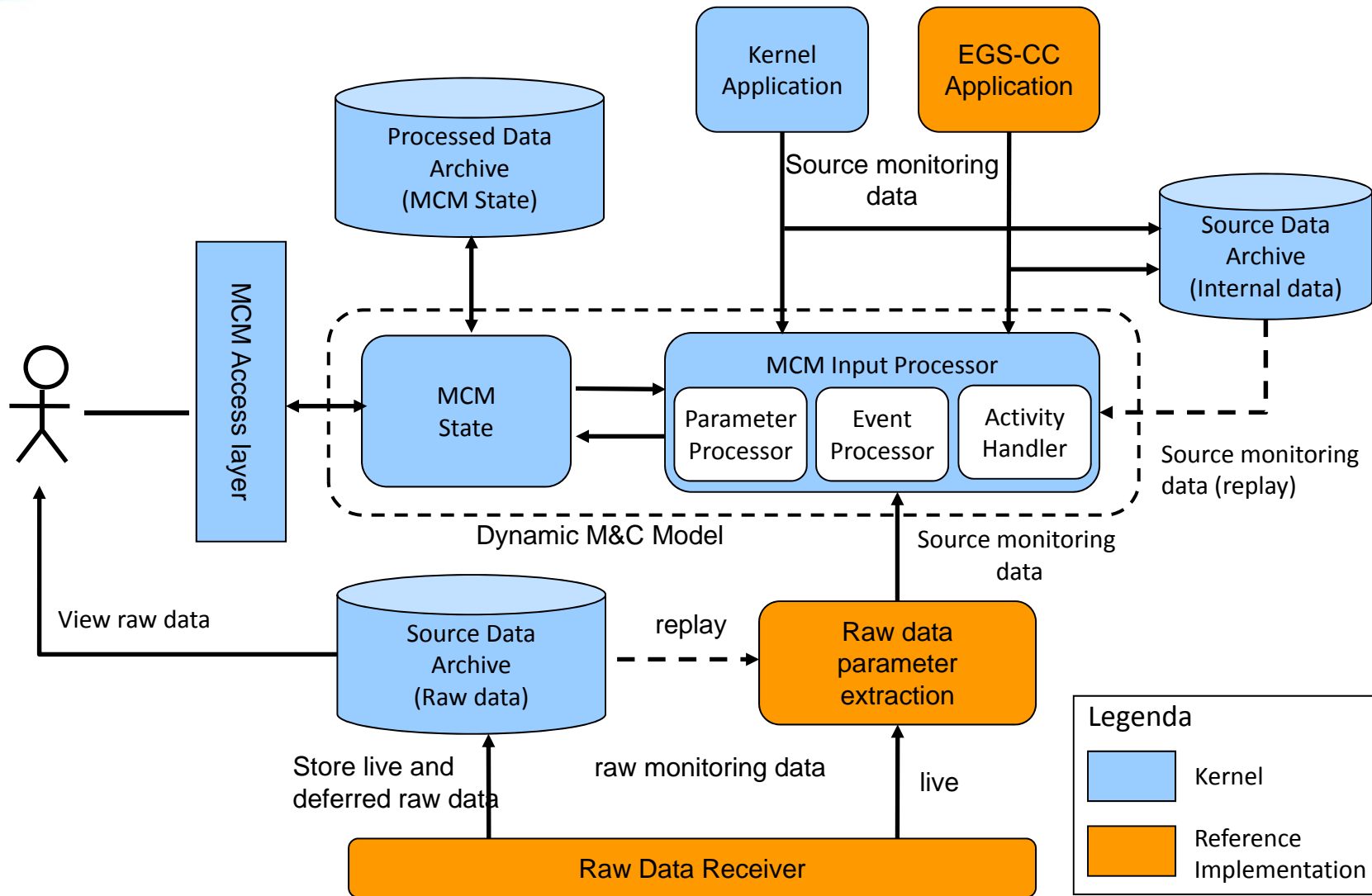

# Data Processing Concept - LIVE

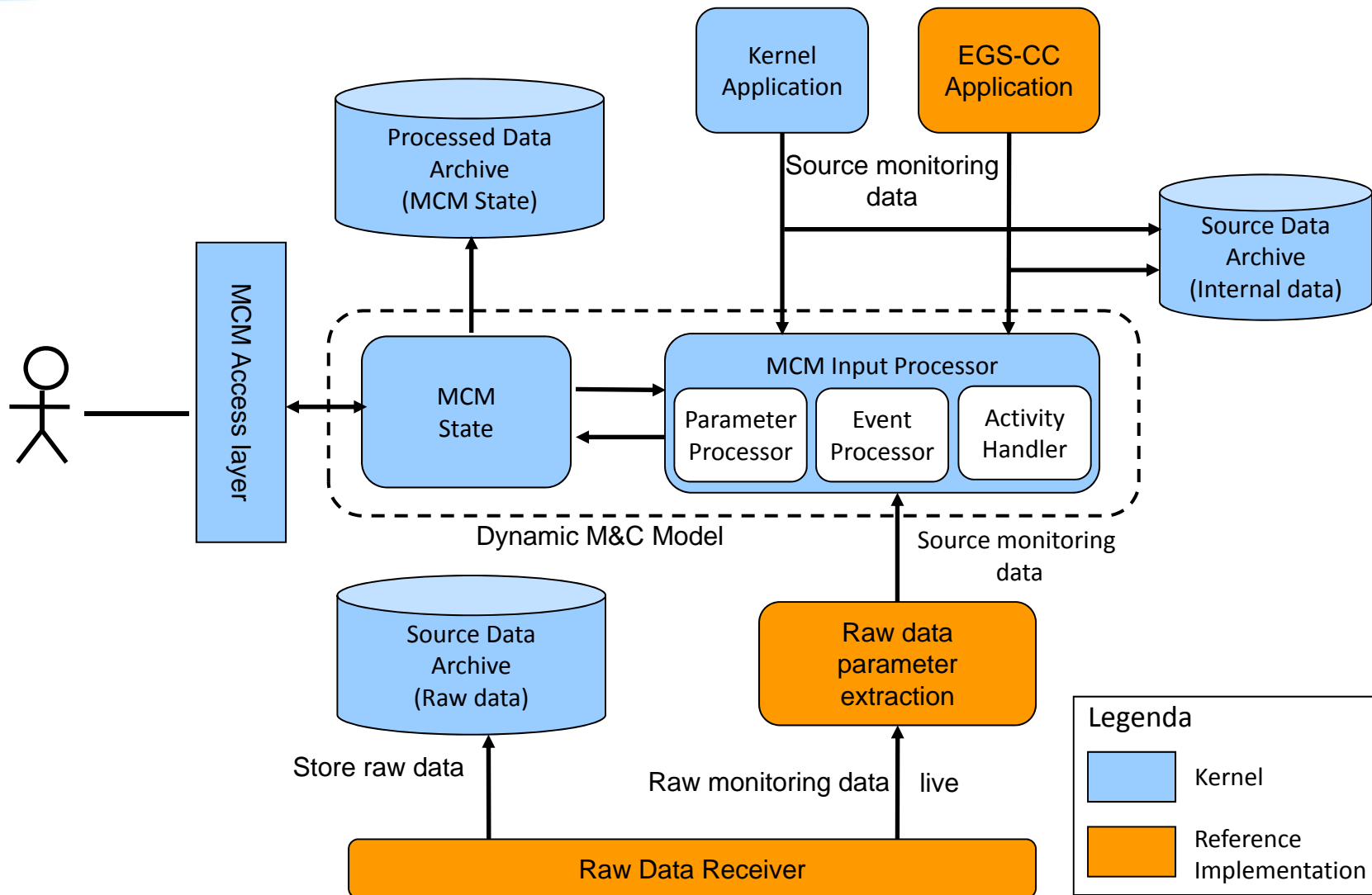

# Data Processing Concept - REPLAY

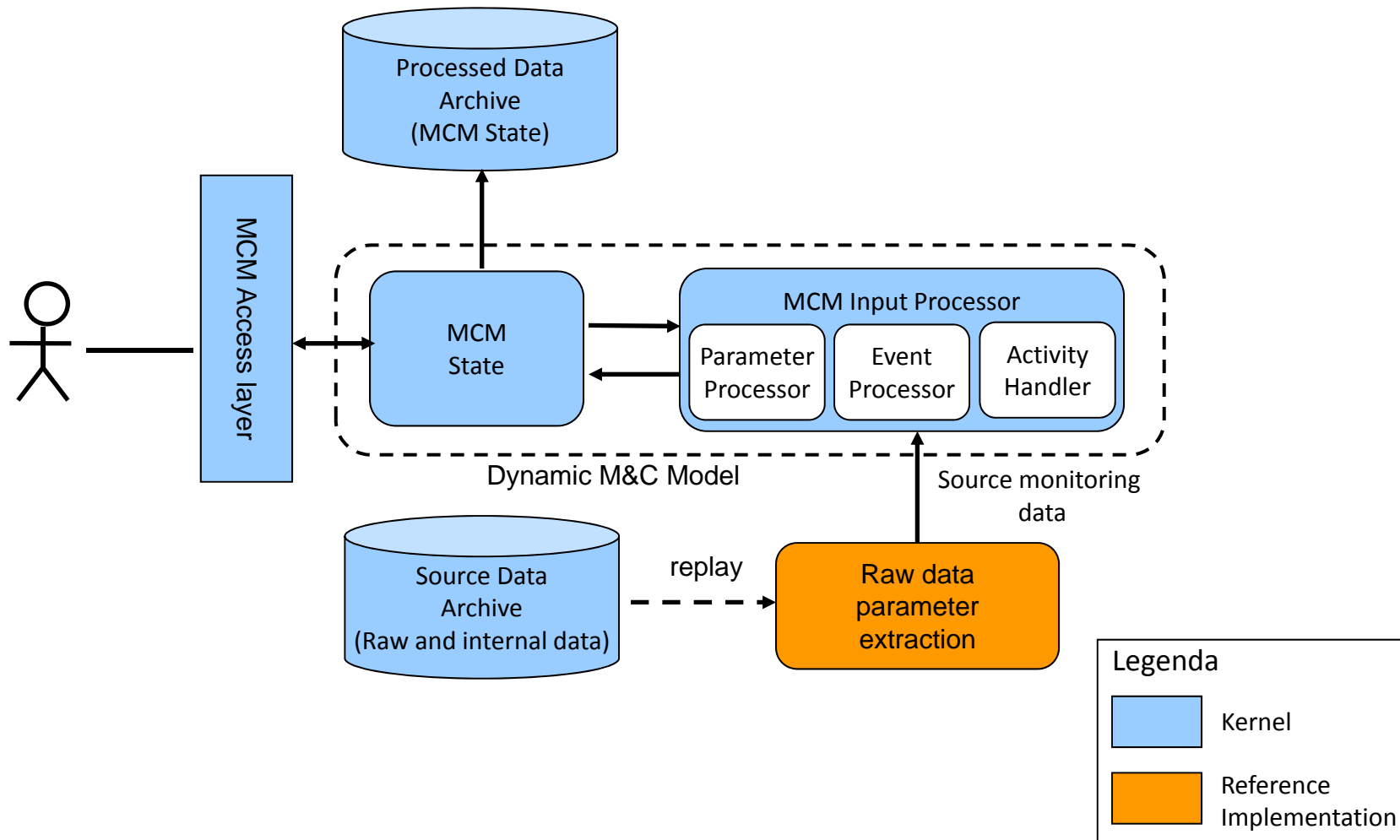

# Data Processing Concept - RETRIEVAL

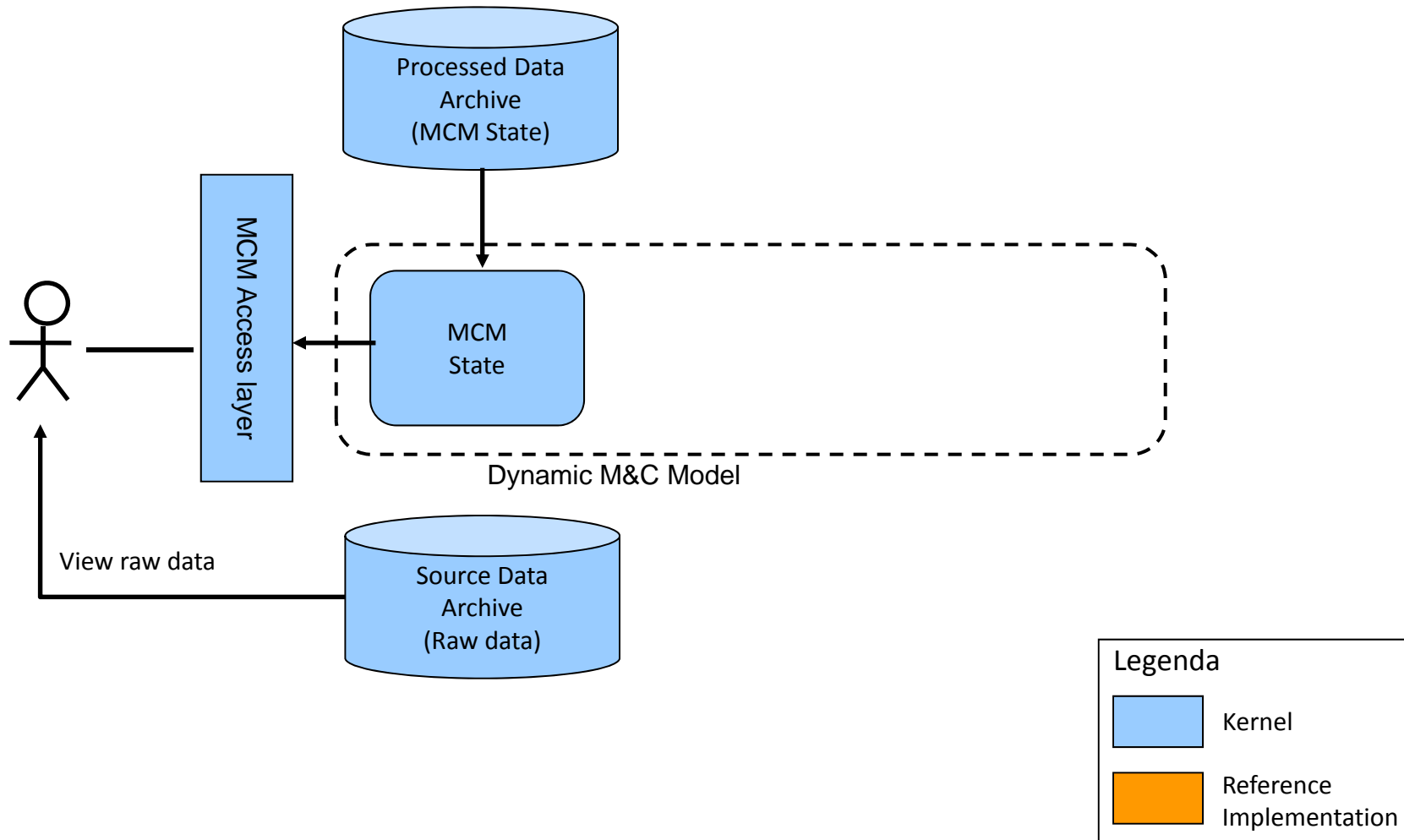

# System Integration Concept

Legenda

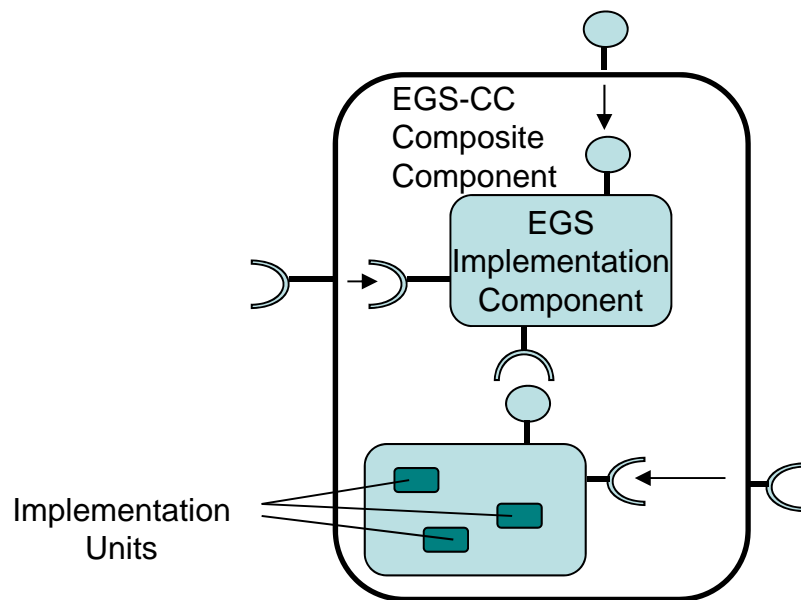
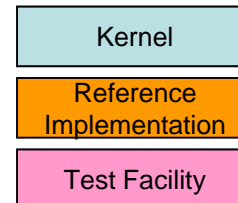

Component Run-Time Platform

# System Integration Concept

Legenda

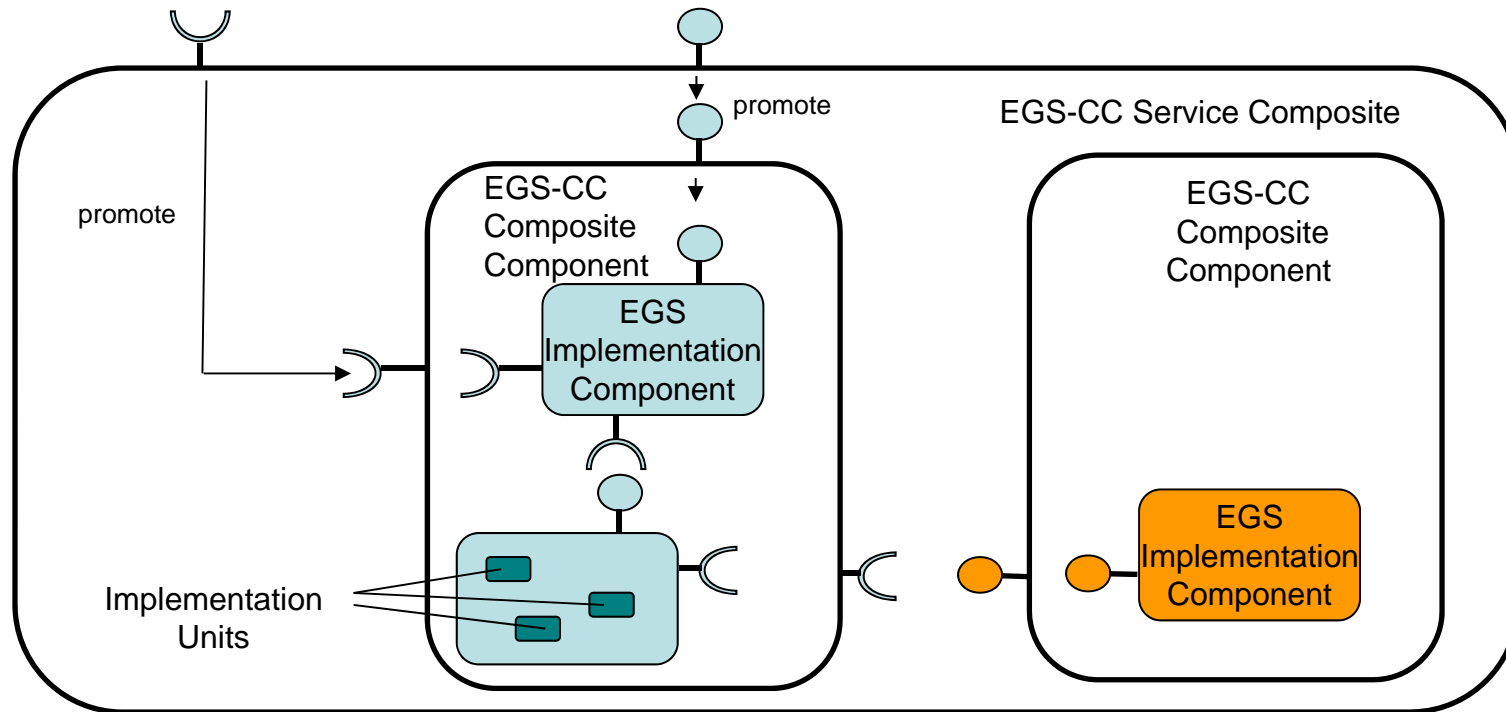
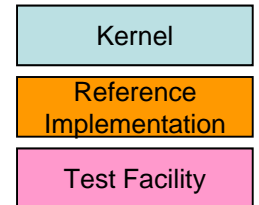

Component Run-Time Platform

# System Integration Concept

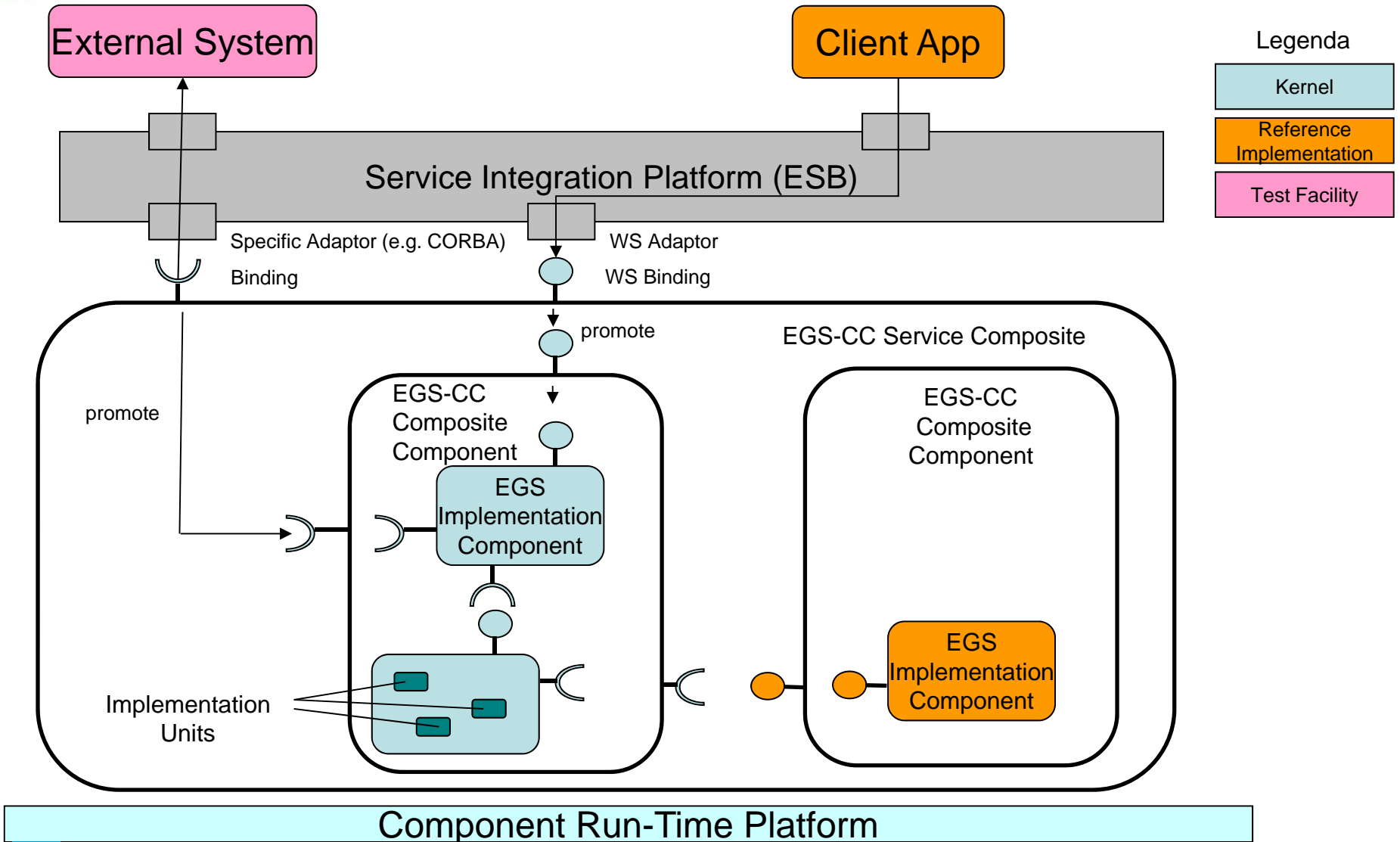

# System of Systems Approaches

- Independent EGS-CC System Instances
- Master / Child setup

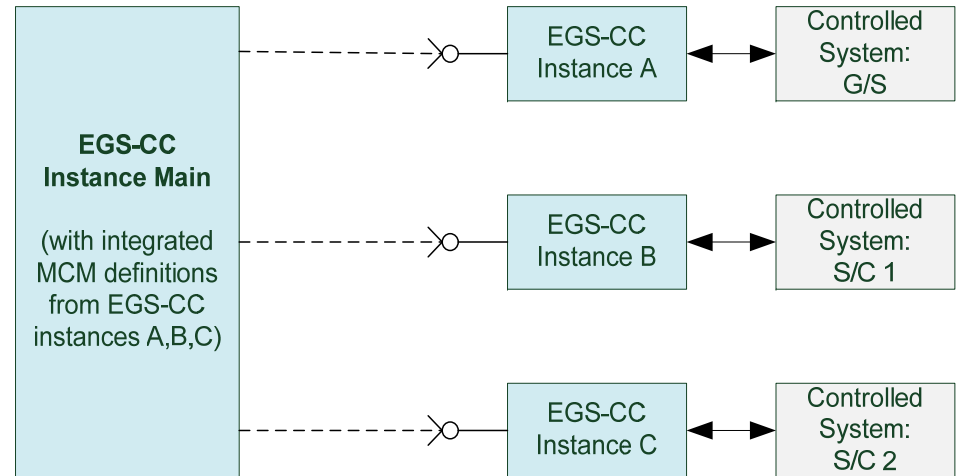

- Merged EGS-CC System Instances

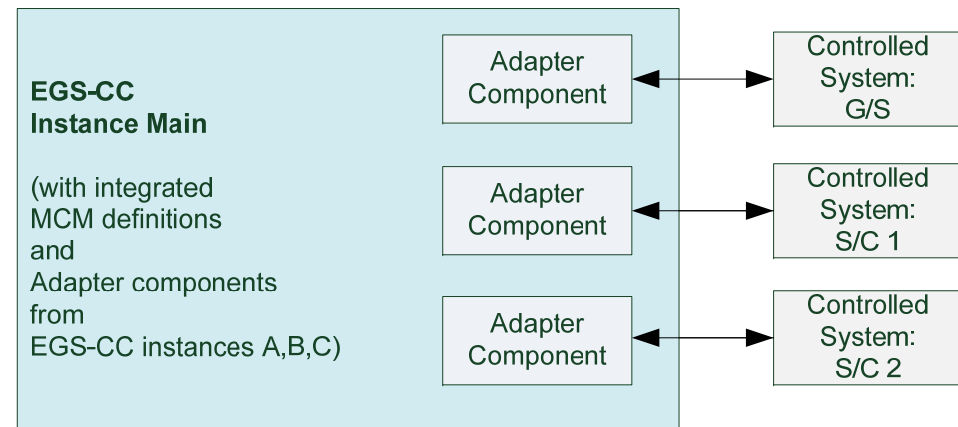



# Technology Selection Process

- Significant use of 3<sup>rd</sup> party technologies/products but trying to avoid invasive dependencies
- Precise/severe technology selection criteria/constraints have been identified
- Areas where re-use of 3<sup>rd</sup> party technologies is expected identified (technology domains)
- Potential candidates for each domain identified
- Linux (+ Windows for the user front-end) and Java selected as basic technologies
- Final selection of the other technologies/products is taking place as part of the Technology Assessment activity taking place in Phase B
- Aim is to define the best fit of technologies meeting the EGS-CC needs (and not necessarily the best selection for each individual domain)

## *(Run-time) Technology Domains*

- Component Framework
- Service Integration Platform
- Communication and Data Distribution
- System Run-Time Management
- Logging
- Security
- User Interface
- User Defined Displays
- Post Processing & Reporting
- Scripting
- Procedures Language
- Expression Language
- File Management
- Data Persistence
- Data Archiving
- Data Modeling and Tooling

## Status and Plans

- Phase A has been recently completed – outputs include
  - Domain analysis, Use cases, User (functional and non-functional) requirements, glossary, system concepts, conceptual architecture, external interfaces identification, preliminary technology assessment
- Phase B just started, including industrial support for:
  - Software Requirements Engineering and Architectural Design
  - Technological Proof of Concept
- Phase C/D expected to start in 2014
  - based on an incremental/iterative approach
  - continuous integration and validation of main deliverables in the target environments (Large System Integrators and Agencies)
- Operational validation through pilot projects for EGSE and MCS applications

# Conclusions

- The EGS-CC initiative is in its early phases
- Strong stakeholders commitment
- Objectives are very ambitious but feasible
- The expected benefits justify the commitment and associated investments
- A phased approach to design and development has been adopted
- System definition (Phase A) completed
- System design (Phase B) just started
- First pilot projects expected to materialise in the 2015-2016 time horizon.

*Thank you for your attention*



# *Bonus Slides*

## Use/adoption of product standards

- TM/TC protocols (ECSS-E-ST-50-03 and 04) for packet based missions
- PUS (ECSS-E-ST-70-41) for missions implementing those services
- On-board control procedures (ECSS-E-ST-70-01)
- M&C data definitions (ECSS-E-ST-70-31)
- Procedures languages requirements (ECSS-E-ST-70-32)
- Standards for exchange of information like TM/TC Data definitions (e.g. XTCE)
- Standards related to services to be used or offered: MAL (CCSDS 521.0-B) and SLE (CCSDS 91x)
- Other standards relevant to the different types of subsystems with which EGS-CC will interface (e.g. MIL bus standards)
- Technology standards (methods and tools associated to the chosen technologies) for areas like:
  - Communications frameworks
  - Components/service frameworks
  - Data models

# MCM Definition and Storage

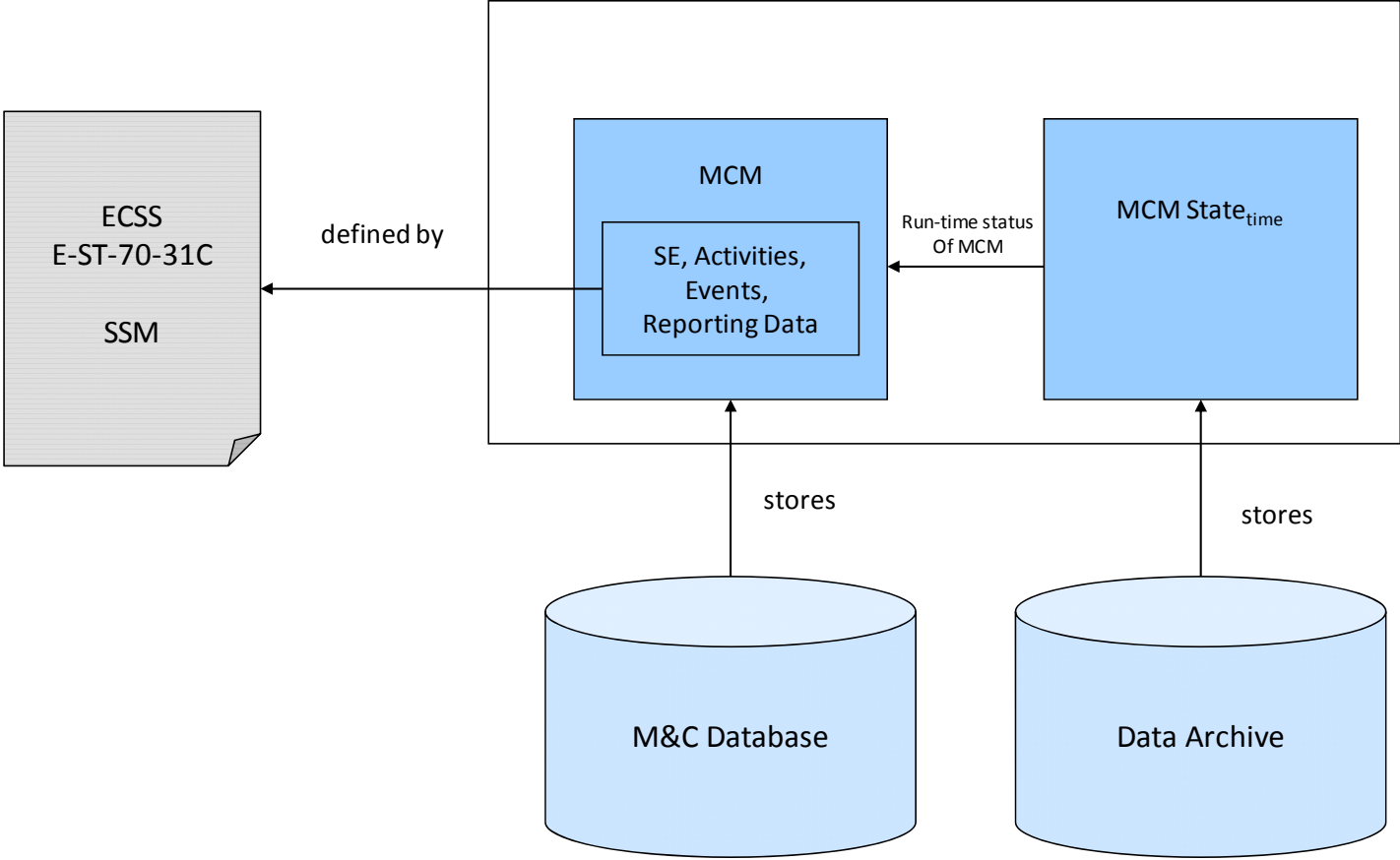



# Monitoring Overview

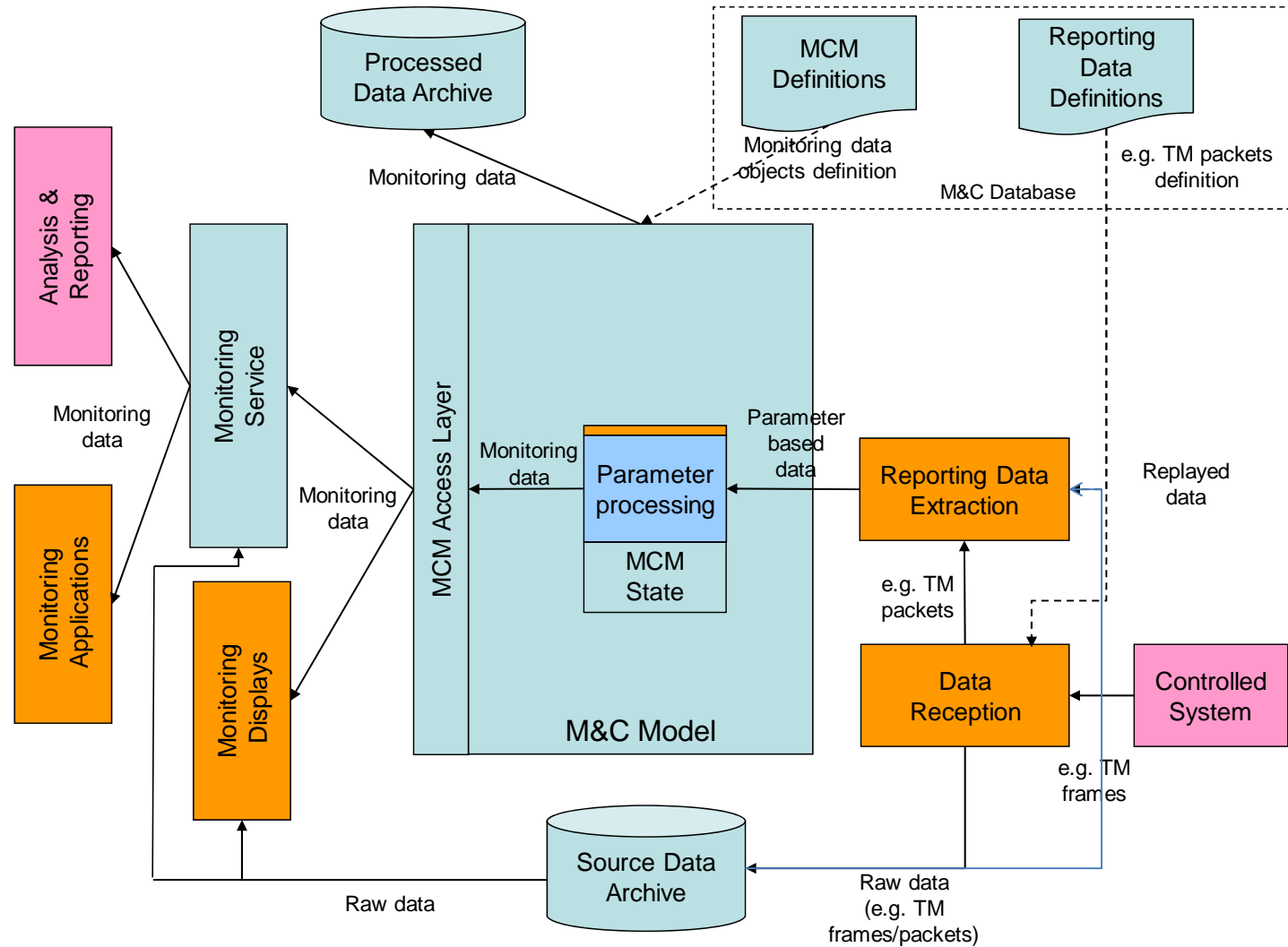

# Control Operations Overview

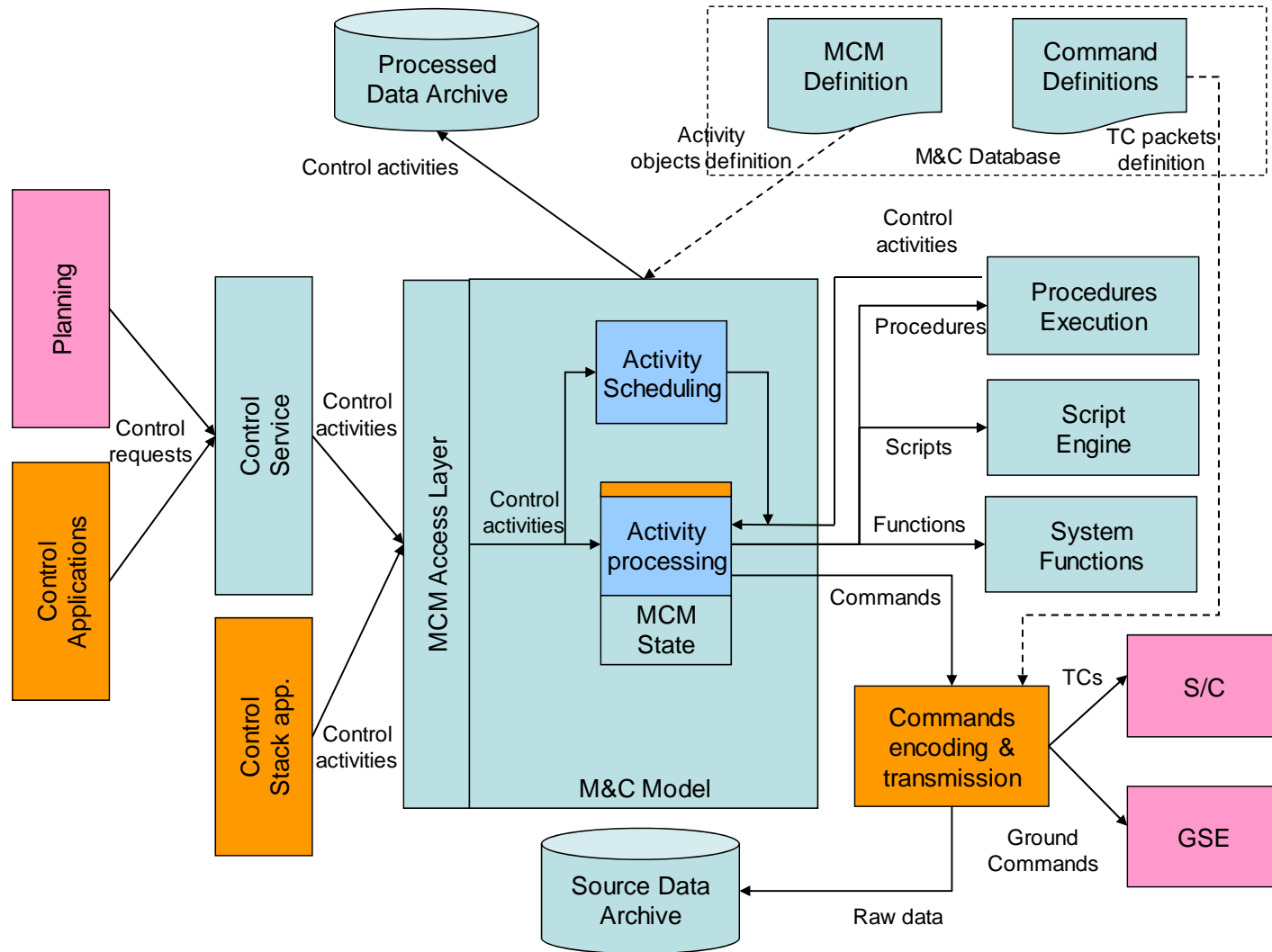

# M&C Components Conceptual Architecture

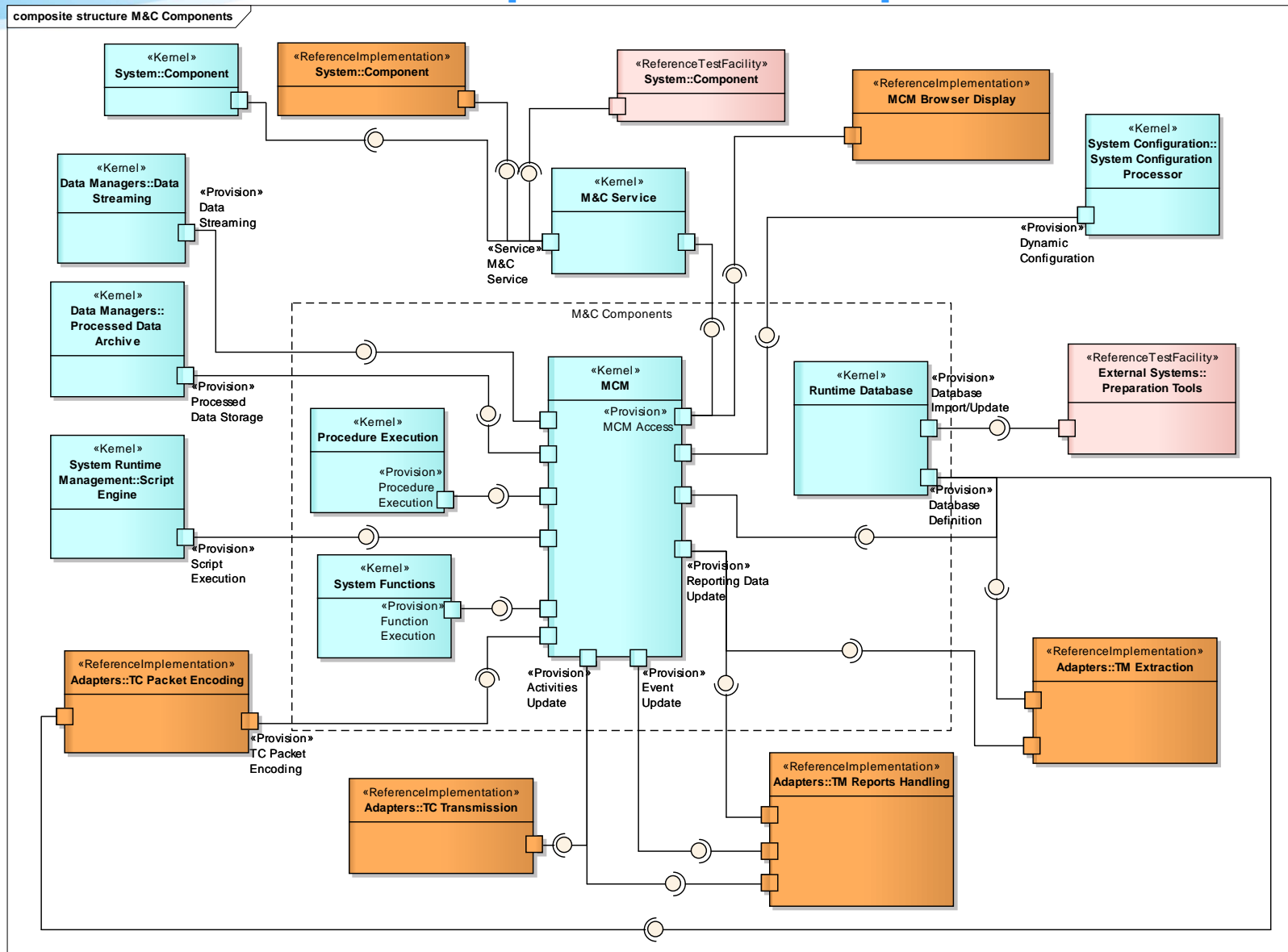

# Conceptual Data Model

## EGS-CC Data Model

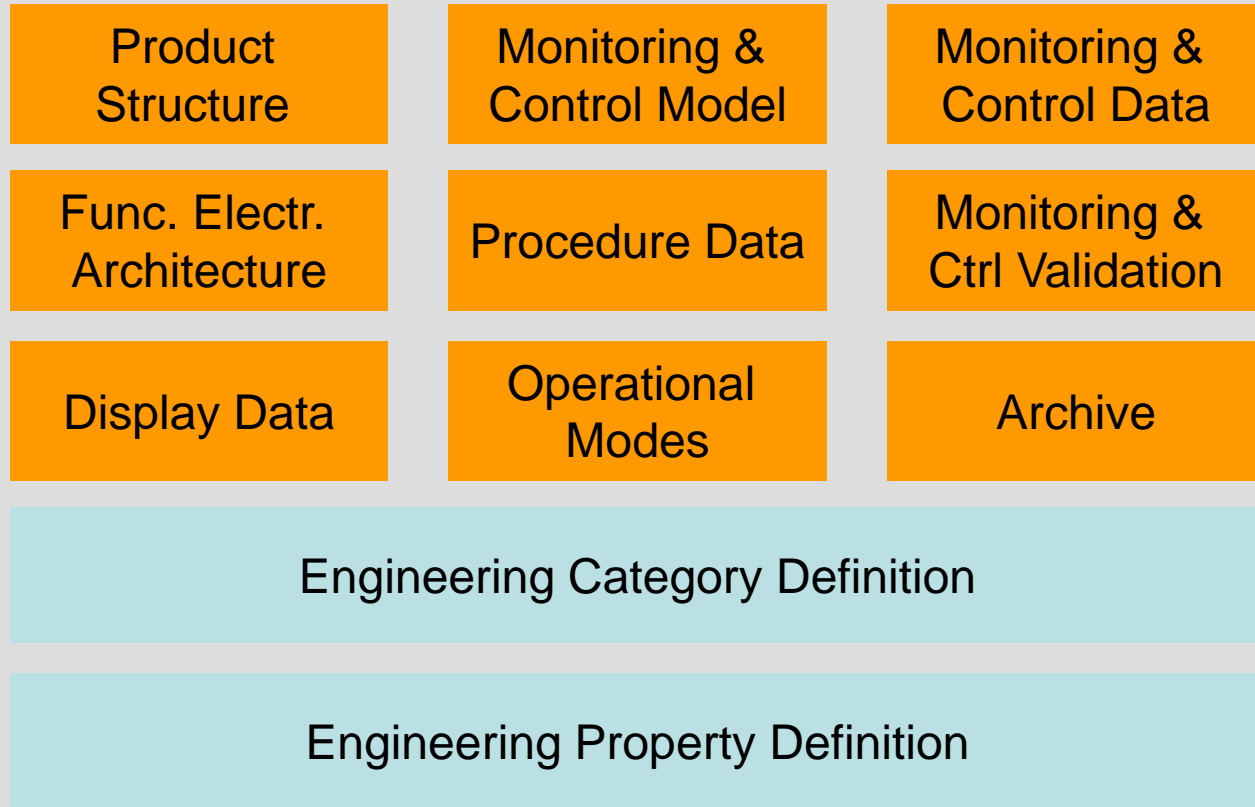

# EGS-CC System Deployment

